

CSR BLUETOOTH MODULES

MB-C04-AT



Specification

Version 1.03

15-AUG-09

1. Hardware & Technical Information

1.1 Pin definition

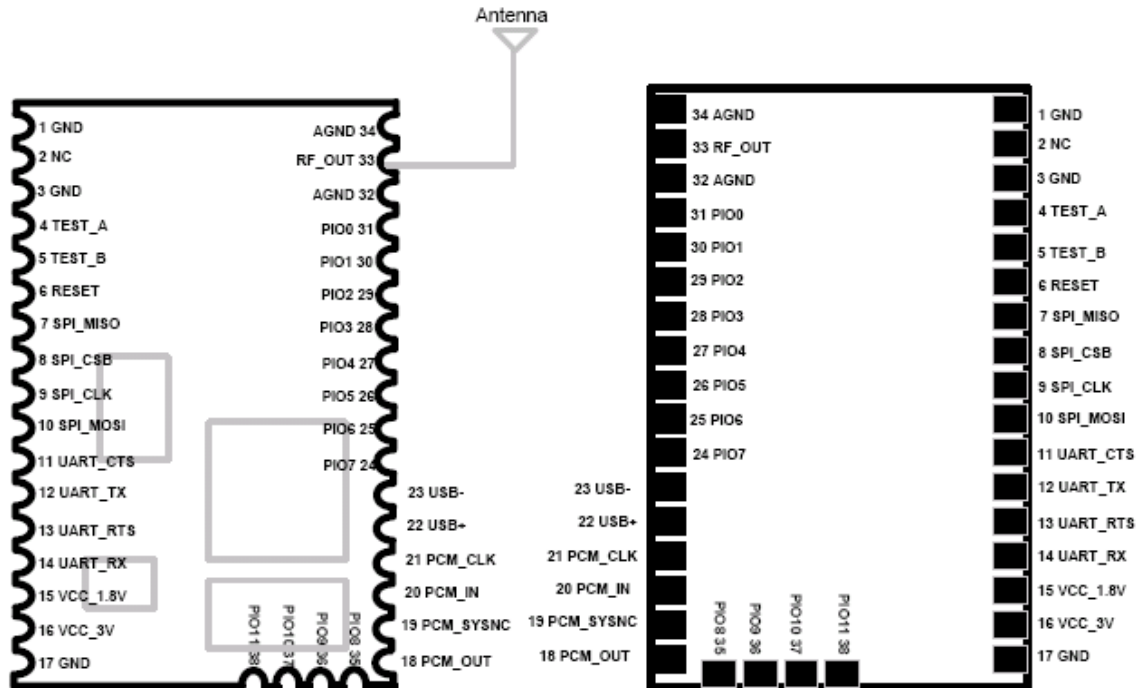

Pin No.	Name	Type	Description	Pin No.	Name	Type	Description
1	GND		Ground connection for digital/analog	34	GND		Ground connection for digital/analog
2	NC		Leave it open	33	RF_OUT	O	RF Output
3	GND		Ground connection for digital/analog	32	GND		Ground connection for digital/analog
4	TestA		Internal test only	31	PIO0	I/O	Programmable input/output line
5	TestB		Internal test only	30	PIO1	I/O	Programmable input/output line
6	Reset	I	Active low for reset. Input debounced so must be high for > 5ms to cause a reset	29	PIO2	I/O	Programmable input/output line
7	SPI_MISO		Serial Peripheral Interface data output	28	PIO3	I/O	Programmable input/output line
8	SPI_CSB		Chip select for Synchronous Serial Interface, active low	27	PIO4	I/O	Programmable input/output line
9	SPI_CLK		Serial Peripheral	26	PIO5	I/O	Programmable

			Interface clock				input/output line
10	SPI_MOSI		Serial Peripheral Interface data input	25	PIO6	I/O	Programmable input/output line
11	UART_CTS	I	UART clear to send active low	24	PIO7	O	
12	UART_TX	O	UART data output	23	USB-		USB data minus(Not implemented)
13	UART_RTS	O	UART request to send active low	22	USB+		USB data plus with selectable internal 1.5 ohm pull-up resistor(Not implemented)
14	UART_RX	I	UART data input	21	PCM_CLK	I/O	Synchronous data clock
15	VCC_1.8V	O	Regulated voltage 1.8V output	20	PCM_IN	I	Synchronous data input
16	VCC_3.3V	I	Voltage supplier from 2.8 to 4V	19	PCM_SYNC	I/O	Synchronous data sync
17	GND		Ground connection for digital/analogy	18	PCM_OUT	O	Synchronous data output

Pin No.	Name	Type	Description	Pin No.	Name	Type	Description
35	PIO8	I/O	Programmable input/output line	37	PIO10	I/O	Programmable input/output line
36	PIO9	I/O	Programmable input/output line	38	PIO11	I/O	Programmable input/output line

1.2 Recommended PCB Layout Outline

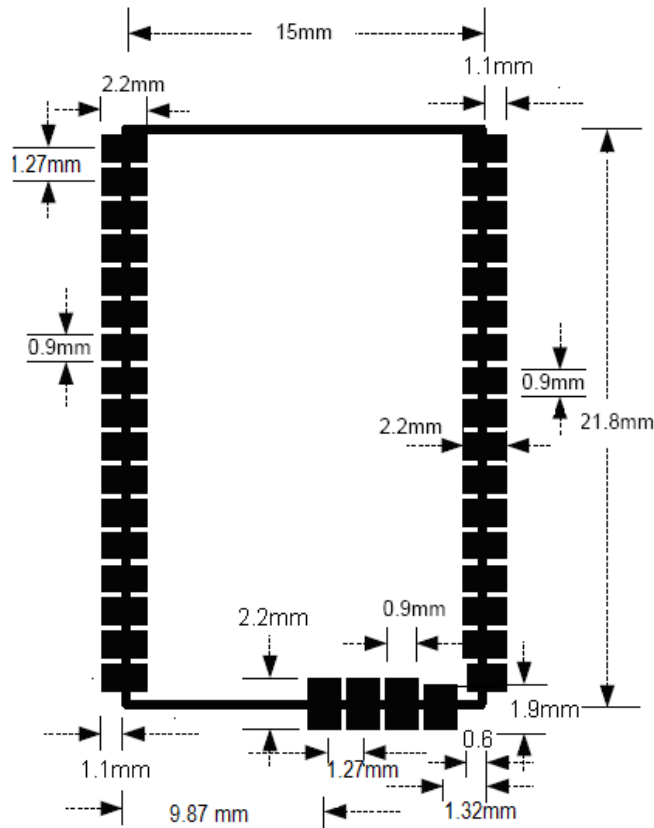

Layout Note:

1. Use solid power and ground planes
2. Ensure there is defined returned path for the signals
3. Power plane extent should be within ground plane extent

1.3 Block Diagram

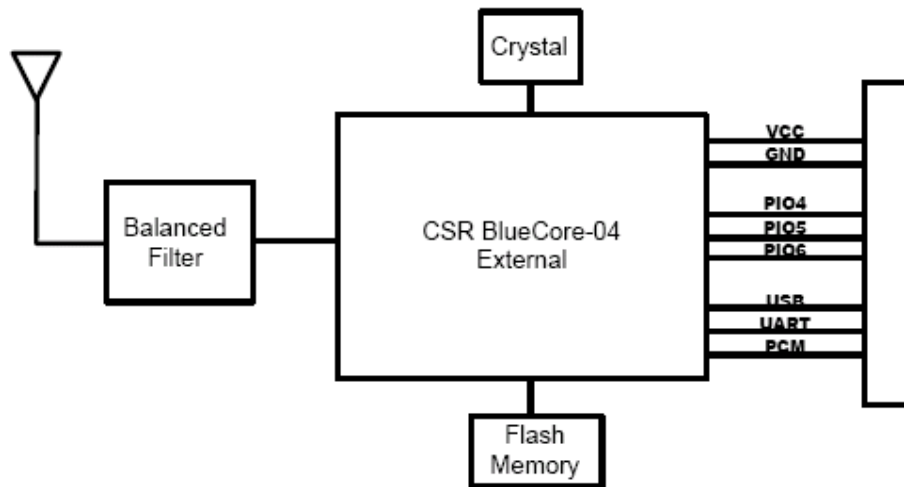

Fig 1.3.1 BT- Class2 Module Block Diagram

1.4 Electrical Characteristics

BT- Class 2

	Min	Typ.	Max.	Unit
Supply Voltage	3.0	3.3	3.6	V
RX Supply Current	-	30	-	mA
TX Supply Current(Normal)	-	40	-	mA
TX Supply Current(Continuous)	-	65	-	mA
Sleep Supply Current	-	1	-	mA
Storage Temperature	-20	-	+85	°C

Power Consumption

Status	Current (mA)	P.S.
Power on, No connection	5.757	
Power on, No connection, Sleep mode	3.127	
Discoverable	26.798	
Discoverable, Sleep enable	25.552	
Connected, sleep mode	8.536	
Connected, No sleep mode	9.033	

LED Status

Status	LED	P.S.
Power on	Flash 6 time	
Power on, No connection	Flash once in 3 seconds	
Power on, Connection	Flash once per second	

■ Operating Conditions

Voltage Range	3.3V±0.3V
Operating Temperature Range	-20 °C ~ 60 °C
Storage Temperature Range	-20 °C ~ 80 °C
Relative Humidity (Operating)	≤90%
Relative Humidity (Storage)	≤90%

1.5 Radio Characteristics

■ BT- Class2 BT2.0 Module

	Frequency (GHz)	Min	Typ	Max	BT Spec.	Unit
Sensitivity at 0.1%BER	2.402	-	-80	-86	≤ -70	dBm
	2.441	-	-80	-86		dBm
	2.480	-	-80	-86		dBm
RF Transmit Power	2.402	-	0	-	≤ 0	dBm
	2.441	-	0	-		dBm
	2.480	-	0	-		dBm
Initial Carrier Frequency Tolerance	2.402	-	5	75	75	kHz
	2.441	-	5	75		kHz
	2.480	-	5	75		kHz
20dB bandwidth for modulated carrier		-	900	1000	≤ 1000	kHz
Drift (Five slots packet)		-	15	-	40	kHz
Drift Rate		-	13	-	20	kHz
$\Delta f_{1\text{avg}}$ "Maximum Modulation"	2.402GHz	140	165	175	$140 < \Delta f_{1\text{avg}}$	kHz
	2.441GHz	140	165	175		kHz
	2.480GHz	140	165	175		kHz
$\Delta f_{2\text{max}}$ "Minimum Modulation"	2.402GHz	115	190	-	115	kHz
	2.441GHz	115	190	-		kHz
	2.480GHz	115	190	-		kHz

Reference Schematics

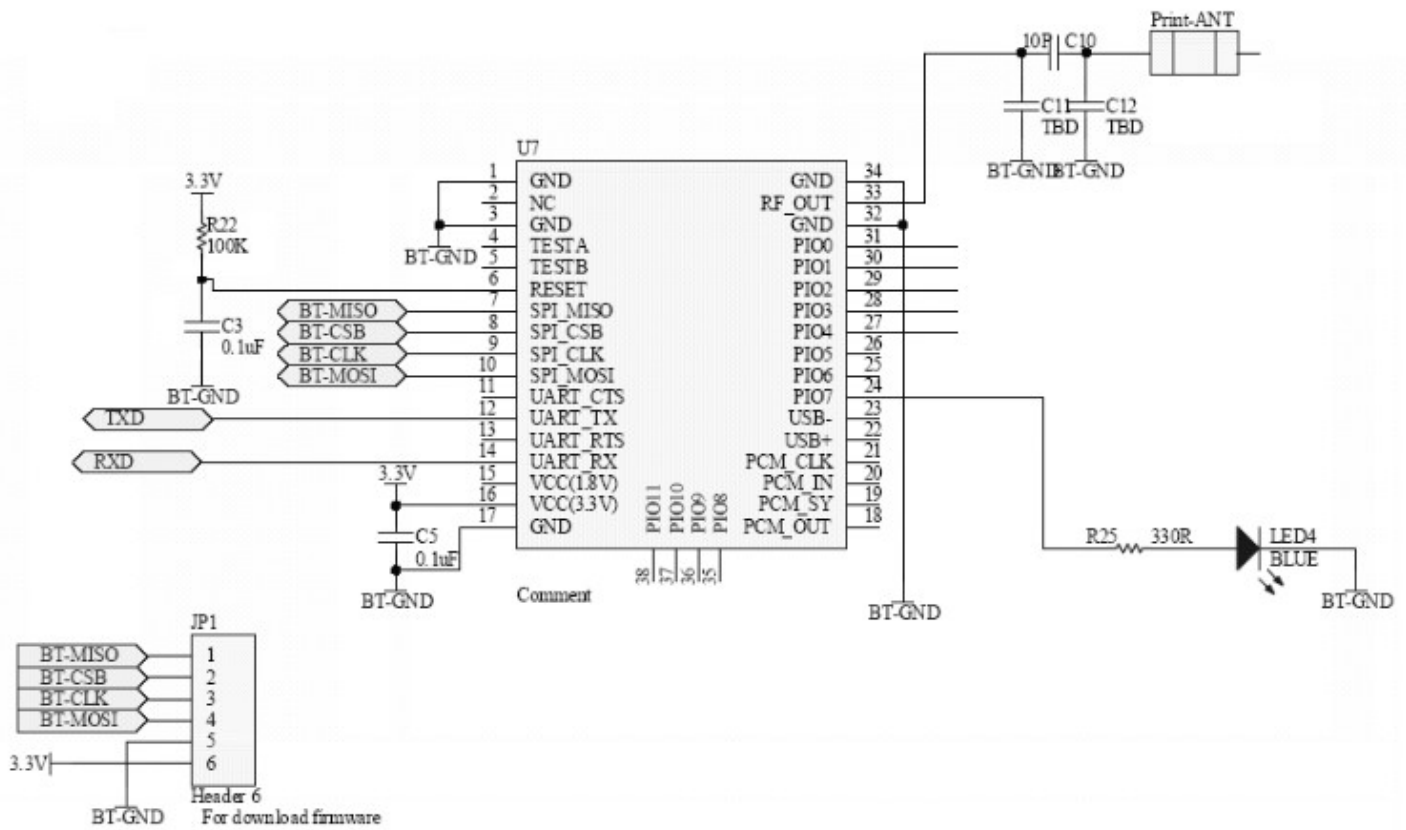

2. Software / Profile

2.1 MB-C04-AT Software function

a. AT command

MB-C04-AT will act only when you send AT command. You can find the detailed command list in “SPP_AT_Commands” document.

3. Standard Setup Information

Parameter		Value	
1	Part number	MB-C04-AT	
2	Baud Rate	9600	
3	Pin Code Prompt	“0000”	
4	Local Name		
5	LED PIN24(PIO 7)	Connected	Flash once per second
		Disconnected	Flash once in 3 seconds

4. Customization Information

Parameter		Value	
1	Part number		
2	Baud Rate		
3	Pin Code Prompt		
4	Local Name		
5	LED PIN24(PIO 7)	Connected	
		Disconnected	